

SWITCHES ROCKER

MINIATURE ROCKER SWITCHES

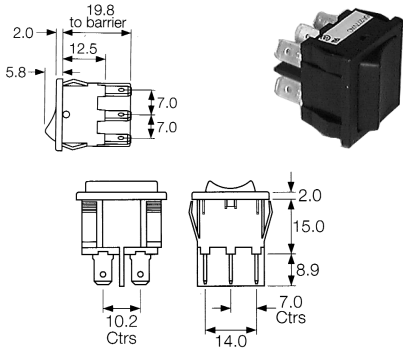

Current Rating:	10A 250VAC, 1/2 Hp @ 277VAC, 1/4 Hp @125VAC
Initial Contact Resistance:	<100Meg Ohms @12VDC
Insulation Resistance:	>20Meg Ohms
Dielectric Strength (Open Contacts):	>1000V for 1 minute
Contact Material:	Silver Alloy
Terminal Material:	Copper Alloy
Body Material:	Nylon 6.6
Actuator & Bezel:	Nylon 6.6
Terminal Type:	.187" Quick Connect

Part No.	Type	Action	Actuator
30-16860*	DPDT	On-(On)	Black Nylon
30-16870	DPDT	On-Off-On	Black Nylon

*note: 30-16860 is 6A @ 277VAC



Mounting Hole: 21.9mm x 19.2mm

() = Momentary

MINIATURE ROCKER SWITCHES

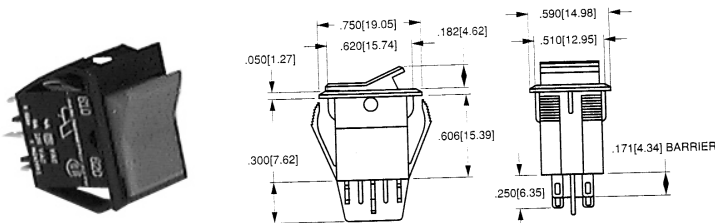

Mounting Hole: 0.515" x 0.625"



SPECIFICATIONS:

Current Rating:	8A @125 V AC, 4A @ 250 V AC
Insulation Resistance:	100 Meg ohms (Min.)
Dielectric Strength:	1000V (Min.)
Base Material:	Nylon
Terminal Type:	Solder

Part No.	Type	Action	Actuator
30-654	DPDT	ON - ON	Red Nylon
30-656	DPDT	ON OFF ON	Red Nylon

SPECIFICATIONS:

ELECTRICAL RATINGS:			
15A	125-250V AC 65C Non Ind	UL E45221	
1/4HP	125V AC 1/2HP 250V AC	UL E45221	
12A	125-250V AC	CSA LR10990	
10 (6)A	250V AC T125	VDE75171	
75A	Inrush	EN61058-1	
10A	28V DC	No Approvals	
MATERIALS:			
Body:	Nylon 6.6		
Rocker (Opaque):	Nylon 6.6		
Contact Gap:	3mm (.118)		
Contact Material:	Silver Alloy		
Part No.	Type	Action	Actuator
30-850	SPST	ON - OFF	Black Nylon & Red
30-852	SPST	ON - OFF	Black Nylon & Green
30-854	SPST	ON - OFF	Black Nylon & Blue
30-855	DPST	ON - OFF	Black Nylon & White



MINIATURE ROCKER SWITCHES

Two Color Actuator with Molded in Color Legend.

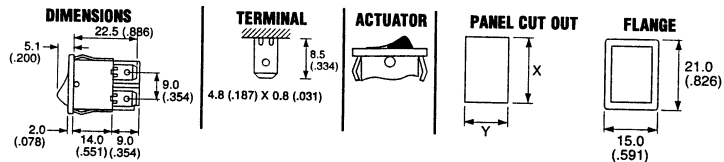

PANEL THICKNESS	DIM X	DIM Y
0.75-1.25	19.2-19.1	13.0-12.9
(.029-.049)	(.756-.752)	(.512-.508)
1.25-2.0	19.4-19.3	13.0-12.9
(.049-.079)	(.764-.760)	(.512-.508)
2.0-3.0	19.8-19.7	13.0-12.9
(.079-.118)	(.779-.776)	(.512-.508)



Industry Standard size. Snap in mounting. Single and Double Pole. ON-OFF Circuits.

STANDARD SIZE ROCKER SWITCHES

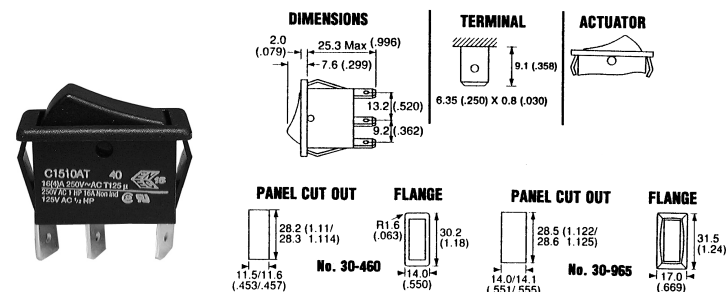

SPECIFICATIONS:

ELECTRICAL RATINGS:			
16A	125-250V AC 85C	UL E45221	
1/2HP	125V AC 1HP 250V AC 2 Position	UL/CSA	
16A	125-250V AC	CSA LR10990	
16 (4)A	250V AC T85	VDE 62411	
20A	28V DC	Approvals N/A	

MATERIALS:			
Body:	Nylon 6.6		
Actuator:	Nylon 6.6		
Contact Gap	(On-Off SP Circuits): 3mm (.118)		
Contact Material:	Silver Alloy		
Part No.	Type	Action	Actuator
30-460	SPDT	ON - OFF	Black Nylon
30-965	SPDT	(ON) OFF (ON)	Black Nylon



NOTE: () = Momentary